



SELF-CONTAINED CRESCENT CUBER

INSTRUCTION MANUAL

**KM-201BAH
KM-260BAH
KM-201BWH
KM-260BWH**

L1F015102 (100109)

IMPORTANT

Only qualified service technicians should install, service and maintain the product. No installation, service or maintenance should be undertaken until the technician has thoroughly read this Instruction Manual. Likewise, the owner/manager should not proceed to operate the product until the installer has instructed them on its proper operation. Failure to install, operate, and maintain the equipment in accordance with this manual may adversely affect safety, performance, component life, and warranty coverage.

Hoshizaki provides this manual primarily to assist qualified service technicians in the installation, maintenance, and service of the product.

Should the reader have any questions or concerns which have not been satisfactorily addressed, please call, write, or send an e-mail message to the Hoshizaki Technical Support Department for assistance.

HOSHIZAKI AMERICA, INC.
618 Highway 74 South
Peachtree City, GA 30269

Attn: Hoshizaki Technical Support Department

Phone: 1-800-233-1940 Technical Support
(770) 487-2331

Fax: 1-800-843-1056
(770) 487-3360

E-mail: techsupport@hoshizaki.com

Web Site: www.hoshizaki.com

NOTE: To expedite assistance, all correspondence/communication MUST include the following information:

* Model Number _____

* Serial Number _____

* Complete and detailed explanation of the problem.

IMPORTANT

1. This booklet is an integral and essential part of the product and should be handed over to the user. Read the warnings contained in this booklet carefully as they give important indications regarding the safety of the installation, use and maintenance. Please preserve this booklet for any further consultation that may be necessary.

2. This icemaker should be destined only to the use for which it has been expressly conceived. Any other use should be considered improper and therefore dangerous. The manufacturer cannot be held responsible for eventual damage caused by improper, incorrect and unreasonable use.

CONTENTS

PAGE

I. Specifications -----	1
A. Nameplate Rating -----	1
B. Dimensions/Connections -----	2
1. KM-201BAH -----	2
2. KM-260BAH -----	3
3. KM-201BWH -----	4
4. KM-260BWH -----	5
II. Installation and Operating Instructions -----	6
A. Checks Before Installation -----	6
B. How to Remove Panels -----	6
C. Location -----	7
D. Electrical Connection -----	8
E. Set Up -----	8
F. Water Supply and Drain Connections -----	9
G. Final Checklist -----	12
H. Startup -----	13
III. Cleaning and Maintenance Instructions -----	14
A. Cleaning -----	14
1. Cleaning Procedure -----	14
2. Sanitizing Procedure - Following Cleaning Procedure -----	16
B. Maintenance -----	17
1. Exterior Panels -----	17
2. Storage Bin and Scoop -----	17
3. Air Filter -----	18
4. Condenser -----	18
C. Preparing the Icemaker for Long Storage -----	18

I. Specifications

A. Nameplate Rating

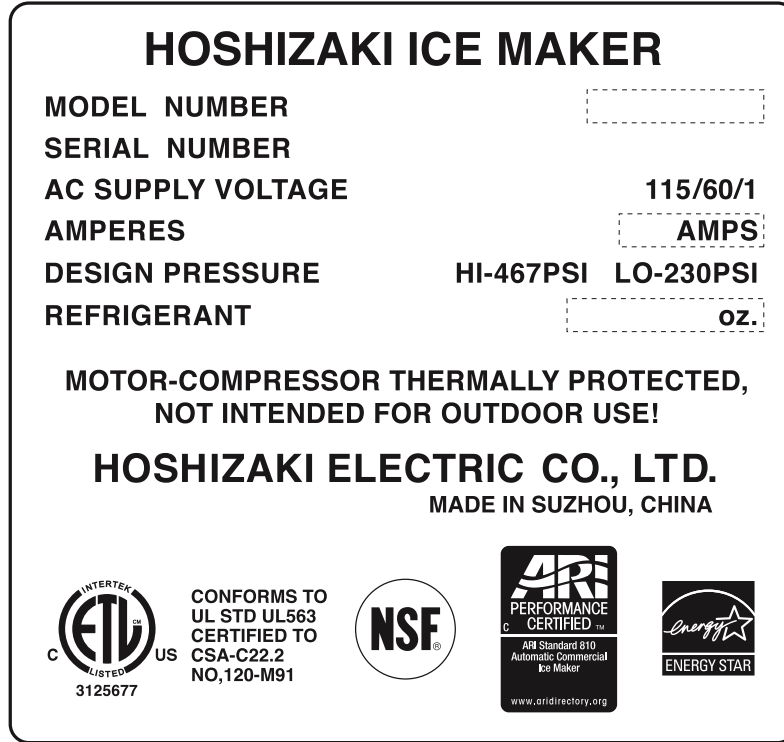

Model	Amperes	Refrigerant	Energy Star
KM-201BAH	6.1 AMPS	R404A 12.0 oz.	Applicable
KM-260BAH	7.6 AMPS	R404A 12.7 oz.	Applicable
KM-201BWH	5.4 AMPS	R404A 10.9 oz.	Not applicable
KM-260BWH	7.1 AMPS	R404A 13.8 oz.	Not applicable

See the Nameplate for electrical and refrigeration specifications. This Nameplate is located inside the Louver.

We reserve the right to make changes in specifications and design without prior notice.

B. Dimensions/Connections

1. KM-201BAH

Unit: mm [inches]

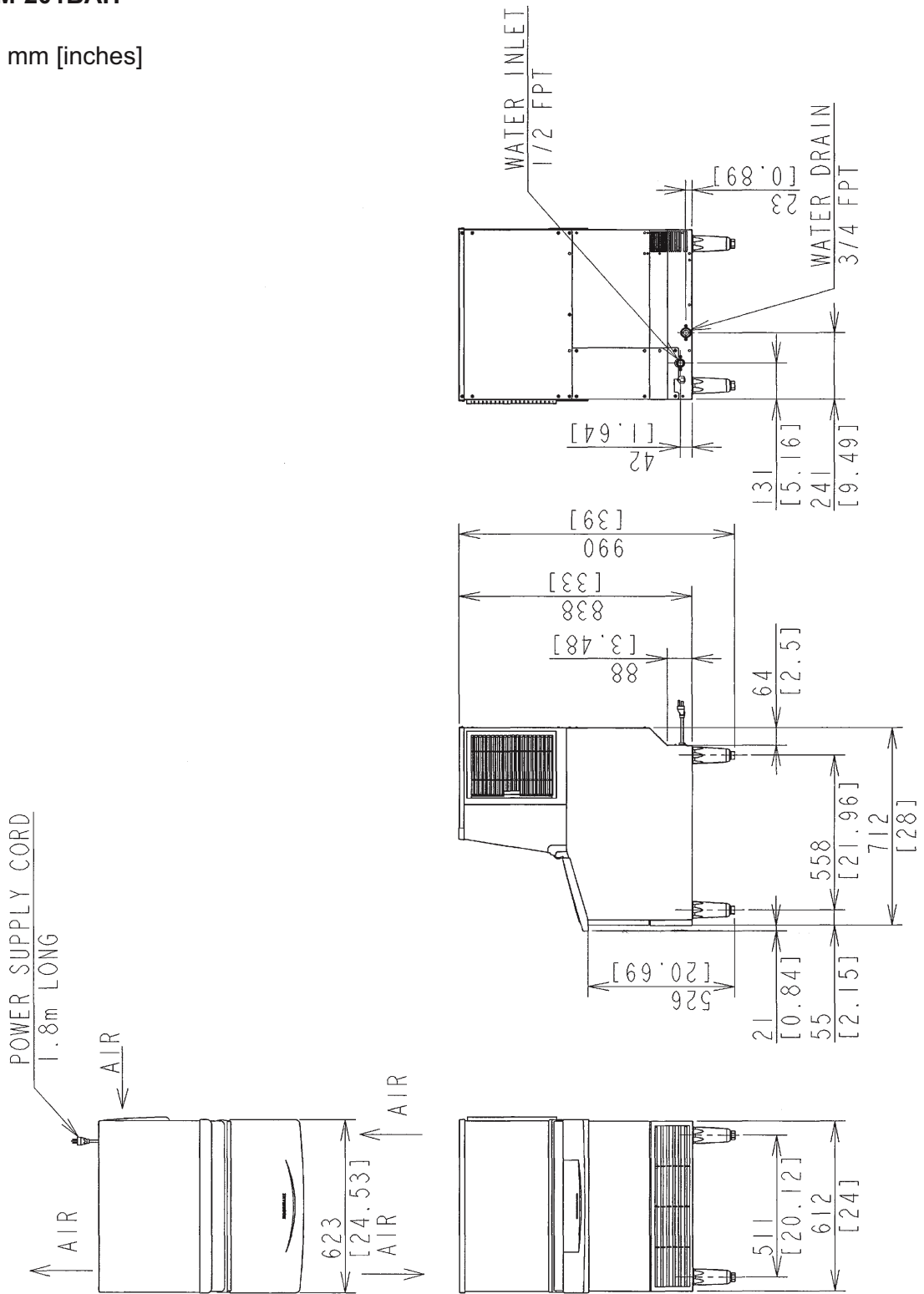

2. KM-260BAH

Unit: mm [inches]

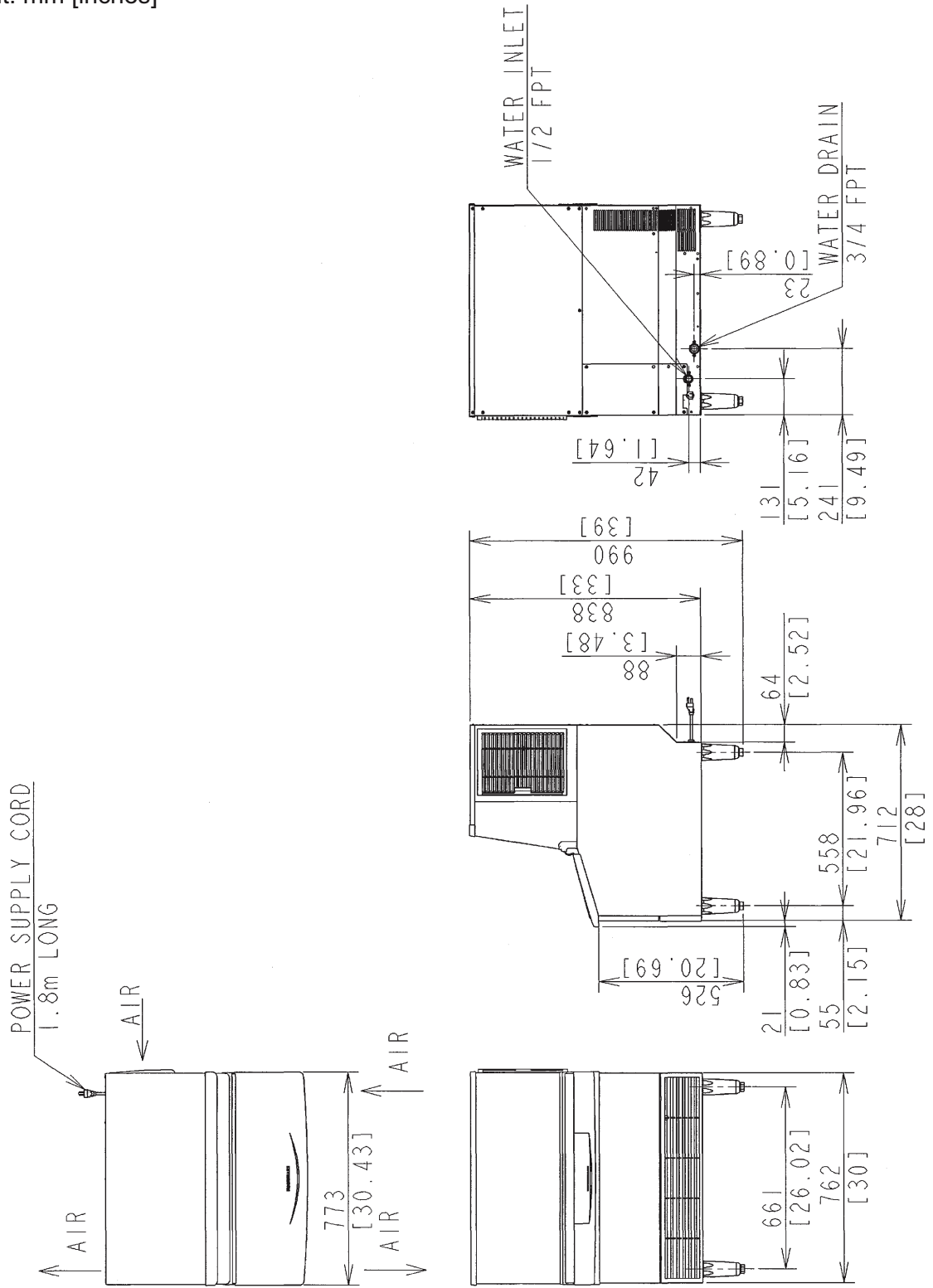

3. KM-201BWH

Unit: mm [inches]

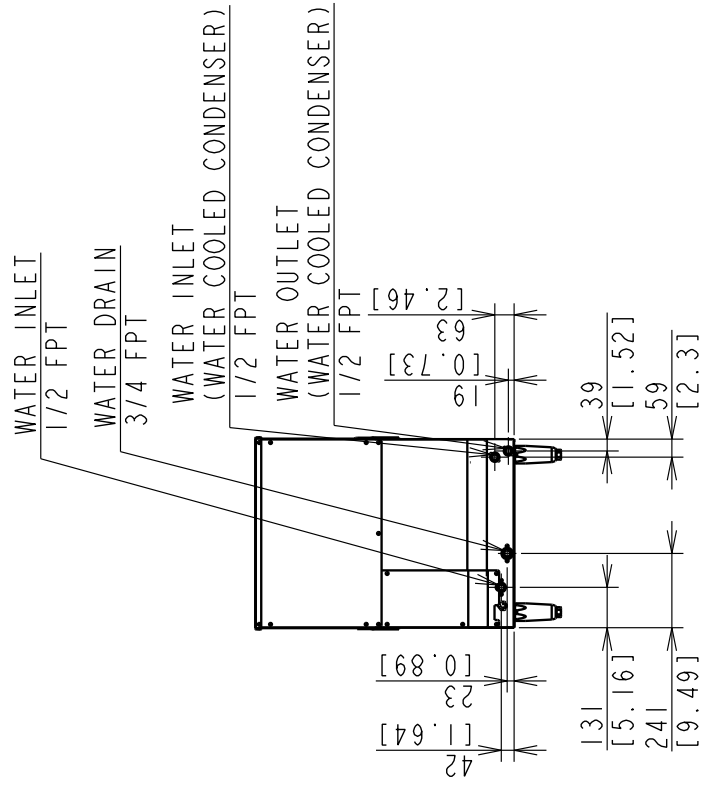
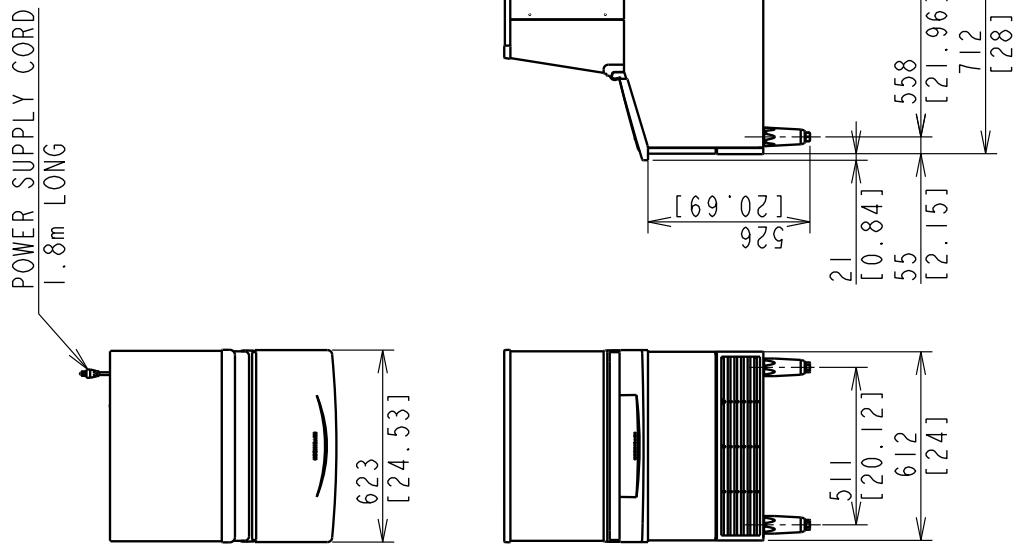

4. KM-260BWH

Unit: mm [inches]

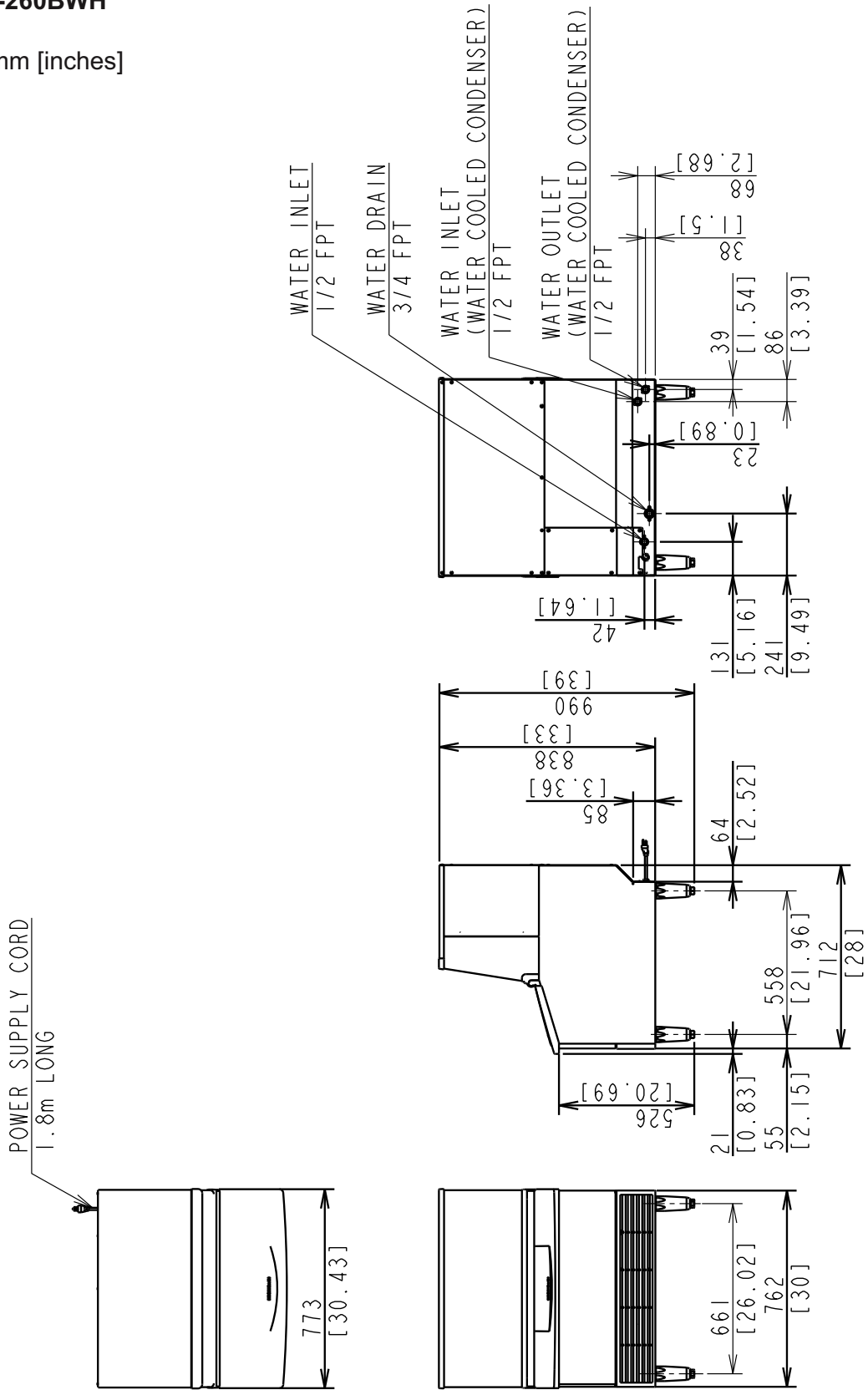

II. Installation and Operating Instructions

A. Checks Before Installation

* Visually inspect the exterior of the shipping container, and any severe damage noted should be reported to the carrier.

IMPORTANT

1. Remove shipping carton, tape(s) and packing. If packing material is left in the icemaker, it will not work properly.
2. Ensure all components, fasteners and thumbscrews are securely in place.
3. Remove the shipping tapes holding the Door and Separator. See Fig. 1.

- 1) Remove the panels to prevent damage when installing the icemaker. (See “B. How to Remove Panels”.)
- 2) Remove the package containing accessories.
- 3) Remove the protective plastic film from the panels. If the icemaker is exposed to the sun or to heat, remove the film after the icemaker cools.
- 4) Check that refrigerant lines do not rub or touch lines or other surfaces, and that the fan blade turns freely.
- 5) Check that the Compressor is snug on all mounting pads.
- 6) See the Nameplate on the upper part of the Left Side Panel, and check that your voltage supplied corresponds with the voltage specified on the Nameplate.

B. How to Remove Panels - See Fig. 1

* Louver: Pull the top towards you, and lift off when the Magnet Catches come off the body.

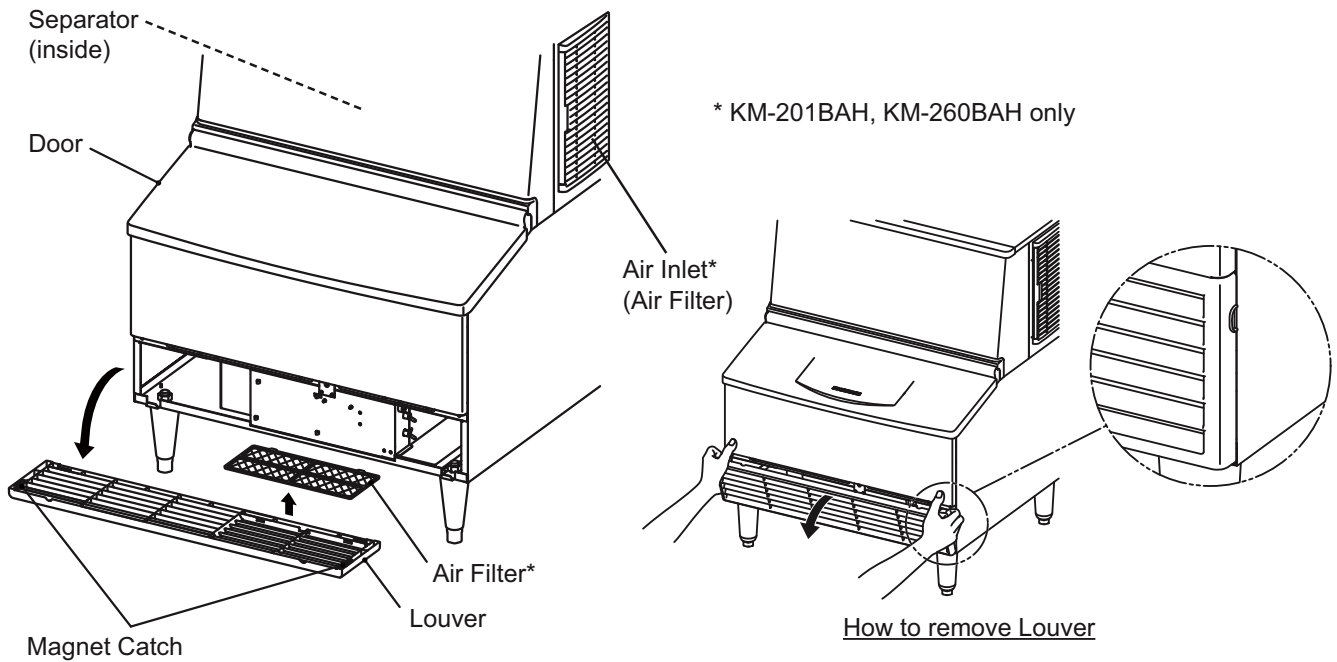

Fig. 1

C. Location

WARNING

This icemaker is not intended for outdoor use. Normal operating ambient temperature should be within +45°F to +100°F (+7°C to +38°C); Normal operating water temperature should be within +45°F to +90°F (+7°C to +32°C). Operation of the icemaker, for extended periods, outside of these normal temperature ranges may affect production capacity.

For best operating results:

- * The icemaker should not be located next to ovens, grills or other high heat producing equipment.
- * Level the icemaker from side to side and front to rear by adjusting the legs. The location should provide a firm and level foundation for the equipment.
- * Avoid a site where dripping is not allowed.
- * This icemaker will not work at subfreezing temperatures. To prevent damage to the water supply line, drain the icemaker when air temperature is below zero.
- * Allow at least 2" (5 cm) clearance at the right side for proper air circulation and at least 0.6" (15 mm) clearance at top for ease of maintenance and/or service.

D. Electrical Connection

WARNING

THIS APPLIANCE MUST BE GROUNDED.

This icemaker requires a ground that meets the national and local electrical code requirements. To prevent possible severe electrical shock injury to individuals or extensive damage to equipment, install a proper ground wire to this icemaker. Remove the plug from the electrical outlet before any maintenance, repairs or cleaning is undertaken.

CAUTION

The GREEN ground wire in the factory-installed power cord is connected to a screw on the bracket where the cord enters the machine. If it becomes necessary to remove or replace the power cord, be sure to connect the power cord's ground wire to this screw upon reattachment.

- * This icemaker must be plugged into an independent power receptacle which has enough capacity. The maximum allowable voltage variation should not exceed ± 10 percent of the nameplate rating. See the Nameplate.
- * Usually an electrical permit and services of a licensed electrician are required.

E. Set Up

IMPORTANT

Do not place heavy objects exceeding 33 lbs (15 kg) on the Top Panel.

- 1) Unpack the icemaker, and remove all shipping cartons, tapes and packing BEFORE operating the unit.
- 2) Position the icemaker in a selected site. Clean the interior with soap and water and rinse thoroughly.
- 3) Level the icemaker in both the left-to-right and the front-to-rear directions (when installed with or without legs). See Fig. 2.
- 4) When installing the unit without legs, the perimeter where the machine touches the counter should be sealed with silicone to prevent water from leaking under the icemaker.
- 5) When installing the unit with legs on the bottom, use the four accessory legs adjustable

from 6" (15.2 cm) to 7" (17.8 cm). Screw the legs tightly into the tapped holes in the base (see Fig. 3). Handle the icemaker carefully not to damage the exterior.

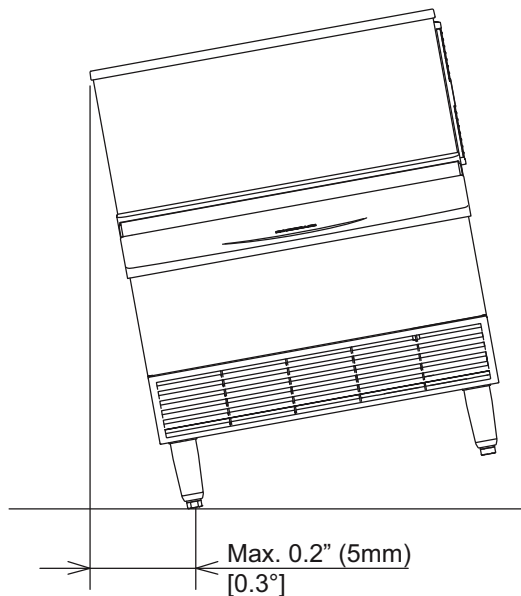

Fig. 2

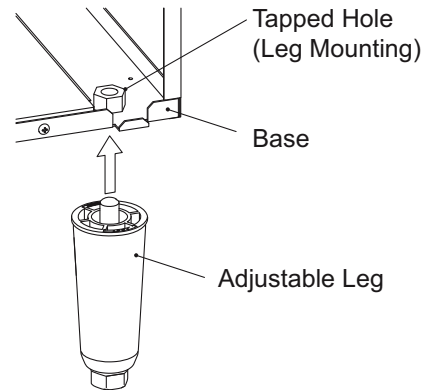

Fig. 3

F. Water Supply and Drain Connections - See Figs. 4 and 5

CAUTION

To prevent damage to equipment, do not operate this icemaker when the water supply is OFF, or if the pressure is below 10 PSIG (0.7 bar). Do not run the icemaker until proper water pressure is reached.

- * Water supply inlet is 1/2" female pipe thread (FPT).
- * A water supply line shut-off valve and drain valve should be installed. A minimum of 3/8" OD copper tubing is recommended for the water supply lines.
- * Water supply pressure should be a minimum of 10 PSIG (0.7 bar) and a maximum of 113 PSIG (7.5 bar). If the pressure exceeds 113 PSIG (7.5 bar), the use of a pressure reducing valve is required.
- * Drain outlet for icemaker dump is 3/4" FPT.
- * Drain lines must have 1/4" fall per foot (2 cm per meter) on horizontal runs to get good flow. A vented tee connection is also required for proper flow.

- * Drain lines should not be piped directly to the sewer system. An air gap of a minimum of 2 vertical inches (5 cm) should be between the end of the drain pipes from the icemaker and the floor drain.
- * This icemaker should be installed in accordance with applicable national, state and local regulations.
- * A plumbing permit and services of a licensed plumber may be required in some areas.

KM-201BAH
KM-260BAH

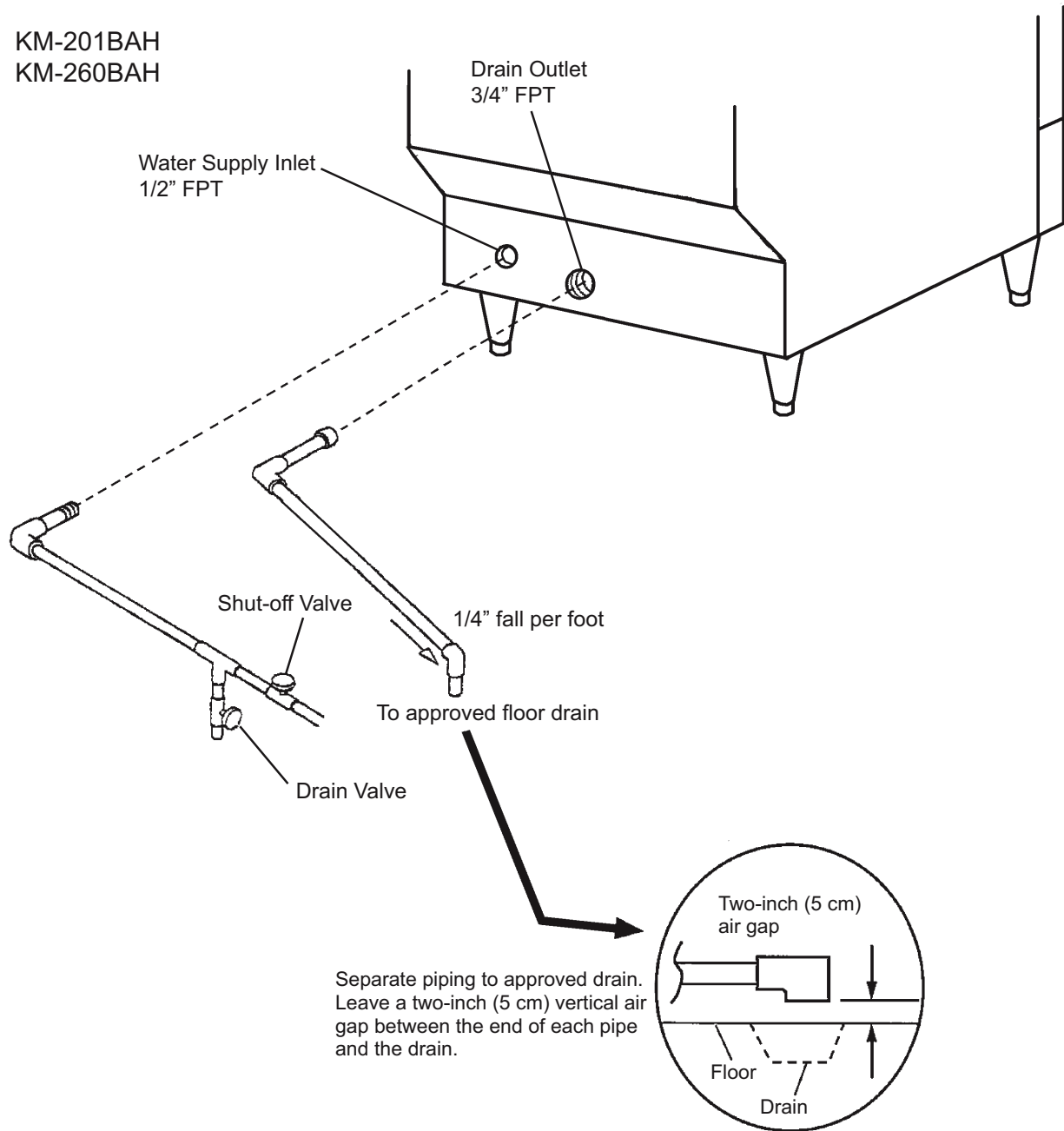

Separate piping to approved drain. Leave a two-inch (5 cm) vertical air gap between the end of each pipe and the drain.

Fig. 4

KM-201BWH
KM-260BWH

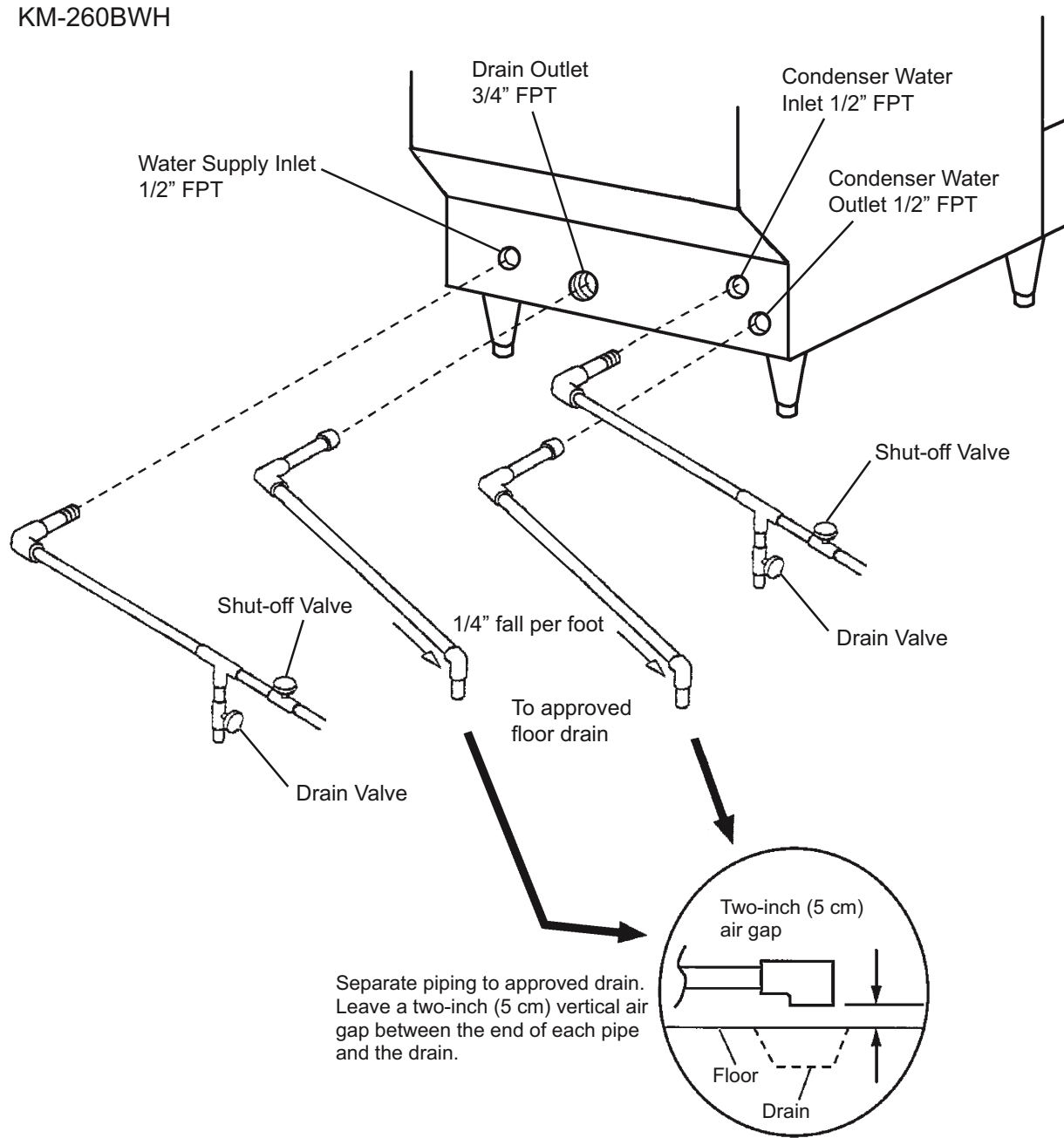

Fig. 5

G. Final Checklist

- 1) Is the icemaker level?
- 2) Is the icemaker in a site where the ambient temperature is within +45°F to +100°F (+7°C to +38°C) and the water temperature within +45°F to +90°F (+7°C to +32°C) all year around?
- 3) Is there at least 2" (5 cm) clearance at the right side for proper air circulation and at least 0.6" (15 mm) clearance at top for ease of maintenance and/or service?
- 4) Have all shipping carton, tape(s) and packing been removed from the icemaker? Is the cube guide in its correct position?
- 5) Are all components, fasteners and screws securely in place?
- 6) Have all electrical and piping connections been made?
- 7) Has the power supply voltage been checked or tested against the nameplate rating? And has a proper ground been installed in the icemaker?
- 8) Are the water supply line Shut-off Valve and Drain Valve installed? Has the water supply pressure been checked to ensure a minimum of 10 PSIG (0.7 bar) and a maximum of 113 PSIG (7.5 bar)?

Note: The icemaker may stop running when the water supply is OFF, or if the pressure is below 10 PSIG (0.7 bar). When the proper water pressure is reached, the icemaker automatically starts running again.
- 9) Have the Compressor hold-down bolts and all refrigerant lines been checked against vibration and possible failure?
- 10) Has the bin control operation been verified?
- 11) Has the end user been given the Instruction Manual and instructed on how to operate the icemaker and the importance of the recommended periodic maintenance?
- 12) Has the end user been given the name and telephone number of an authorized service agent?
- 13) Has the warranty card been filled out and forwarded to the factory for warranty registration?

H. Startup

CAUTION

1. All parts are factory-adjusted. Improper adjustments may result in failure.
2. If the unit is turned off, wait for at least 3 minutes before restarting the icemaker to prevent damage to the Compressor.
3. To prevent damage to the Water Pump, do not leave the Control Switch in the "SERVICE" position for extended periods of time when the Water Tank is empty.

- 1) Open the Water Supply Line Shut-off Valve.
- 2) Remove the Louver.
- 3) Move the Control Switch on the Control Box to the "ICE" position.
- 4) Turn on the power supply and allow the icemaker to operate for 5 minutes to fill up the Water Tank.
- 5) Move the Control Switch to the "SERVICE" position. Move the Service Switch to the "WASH" position.
- 6) Allow the icemaker to run for 5 minutes.
- 7) Move the Service Switch to the "DRAIN" position.
- 8) Allow the icemaker to drain for 2 minutes.
- 9) Turn off the power supply.
- 10) Move the Control Switch to the "ICE" position.
- 11) Replace the Louver in its correct position.
- 12) Clean the Storage Bin using a neutral cleaner. Rinse thoroughly after cleaning.
- 13) Turn on the power supply to start the automatic icemaking process.

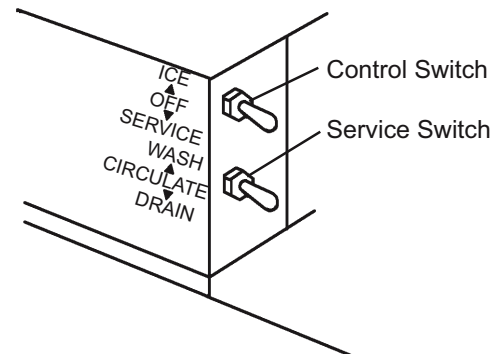
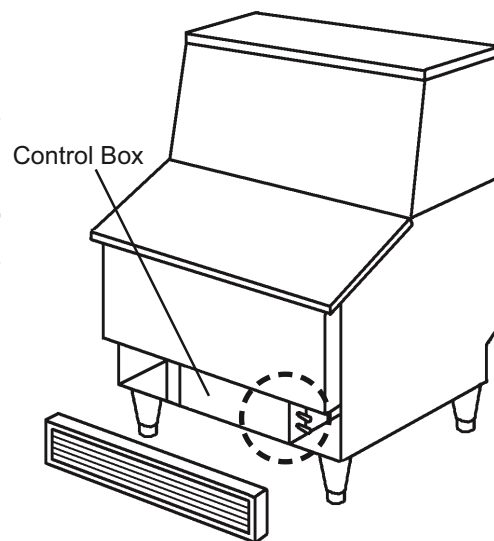

Fig. 6

III. Cleaning and Maintenance Instructions

IMPORTANT

Ensure all components, fasteners and screws are securely in place after any maintenance or cleaning is done to the equipment.

A. Cleaning

WARNING

1. Hoshizaki recommends cleaning this unit at least once a year. More frequent cleaning, however, may be required in some existing water conditions.
2. To prevent injury to individuals and damage to the icemaker, do not use ammonia type cleaners.
3. Always wear liquid-proof gloves to prevent the cleaning and sanitizing solutions from coming into contact with skin.
4. For safety and maximum effectiveness, use cleaning and sanitizing solutions immediately after dilution.

1. Cleaning Procedure

- 1) Dilute 5 fl. oz. (148 ml) of recommended cleaner Hoshizaki "Scale Away" or "LIME-A-WAY" (Economics Laboratory, Inc.) with 1 gallon (3.8 lit.) of water.
- 2) Remove the Louver. Open the Door and remove all ice from the Evaporator and the Storage Bin.

Note: To remove cubes on the Evaporator, move the Control Switch on the Control Box to the "OFF" position and move it back to the "ICE" position after 3 minutes. The defrost cycle starts and the cubes will be removed from the Evaporator.

- 3) Move the Control Switch to the "OFF" position.
- 4) Move the Control Switch to the "SERVICE" position and the Service Switch to the "DRAIN" position.
- 5) After 2 minutes, move the Control Switch to the "OFF" position.
- 6) Pour the cleaning solution into the Water Tank. Move the Control Switch to the "SERVICE" position and the Service Switch to the "WASH" position. Close the Door.

- 7) After 30 minutes, move the Control Switch to the "OFF" position.
- 8) Same as step 4.
- 9) Move the Control Switch to the "ICE" position to fill the Water Tank with water.
- 10) After 3 minutes, move the Control Switch to the "SERVICE" position and the Service Switch to the "WASH" position.
- 11) After 5 minutes, move the Control Switch to the "OFF" position.
- 12) Same as step 4.
- 13) Repeat steps 9 through 12 three more times to rinse thoroughly.
- 14) Disconnect the Overflow Pipe. Next, remove the Water Tank by removing the two Thumbscrews and pulling the tank towards you slightly and pushing it down. Be careful to avoid breakage when handling the parts. See Fig. 7.

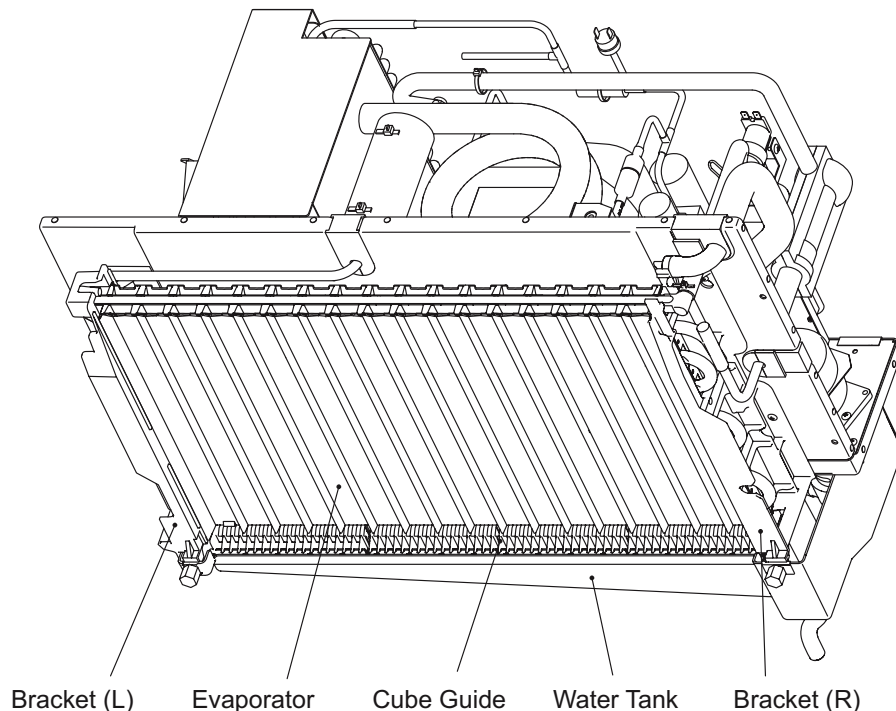
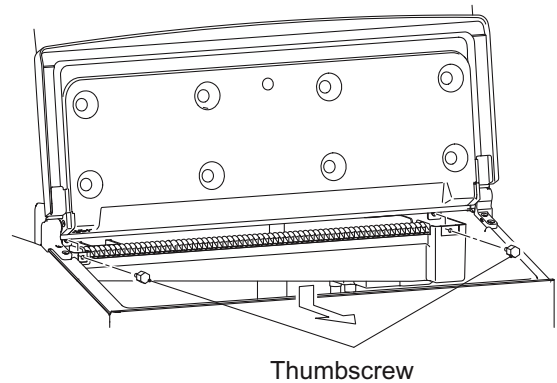

Fig. 7

15) Pull the Cube Guides (quantity varies depending on model) upward to remove them from the Water Tank. They are snapped in place. See Fig. 8.

16) Same as step 1.

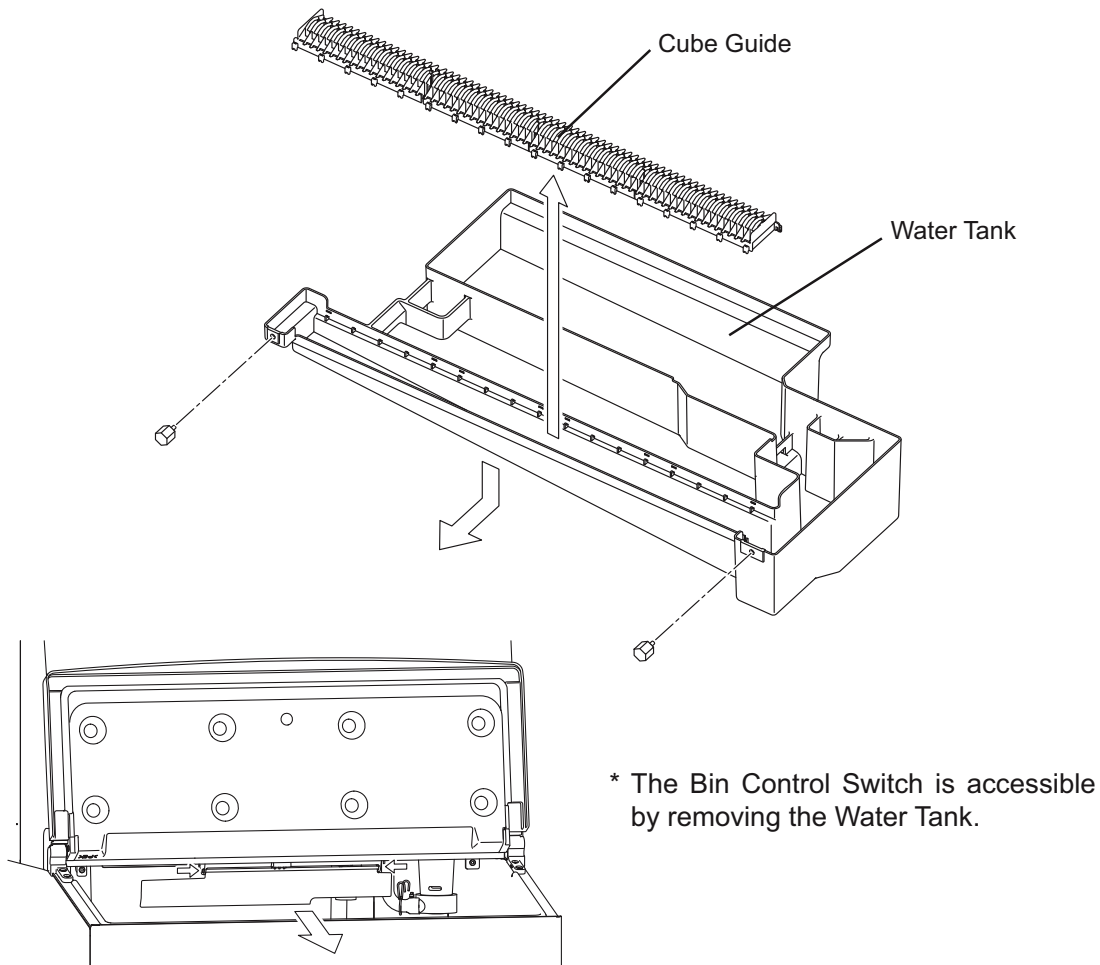

Fig. 8

17) Wash the Bin Control Switch, Water Tank, Float Switch, Cube Guide and Overflow Pipe by using a nylon scouring pad, brushes and the cleaning solution. In addition to the removed parts, also wash the bin liner and Bracket (L) (R) with the solution.

18) Discard the cleaning solution and rinse the parts thoroughly with water.

2. Sanitizing Procedure - Following Cleaning Procedure

1) Dilute approximately 0.5 fl. oz. (15 ml or 1 tbs) of a 5.25% sodium hypochlorite solution (chlorine bleach) with 1 gallon (3.8 lit.) of warm water. Using a chlorine test strip or other method, confirm that you have a concentration of about 200 ppm.

- 2) Soak the removed parts from step 17 above in a clean container containing the sanitizing solution. After allowing the parts to soak for 10 minutes, wash them with the solution. Also wash the bin liner, Bracket (L) (R) with the solution.
- 3) Discard the sanitizing solution and rinse the parts thoroughly with water.
- 4) Replace the removed parts in their correct positions in the reverse order of which they were removed.
- 5) Same as step 1.
- 6) Pour the sanitizing solution into the Water Tank, and allow the sanitizer to sit for 10 minutes.
- 7) Move the Control Switch to the "SERVICE" position and the Service Switch to the "WASH" position.
- 8) After 15 minutes, move the Control Switch to the "OFF" position.
- 9) Move the Control Switch to the "SERVICE" position and the Service Switch to the "DRAIN" position.
- 10) After 2 minutes, move the Control Switch to the "OFF" position.
- 11) Repeat steps 5 through 10 one time. Repeat steps 9 through 12 in the Cleaning Procedure three times to rinse thoroughly.
- 12) Flush the Storage Bin with water.
- 13) Move the Control Switch to the "ICE" position, and start the automatic icemaking process.
- 14) Close the Door. Replace the Louver in its correct position.

B. Maintenance

1. Exterior Panels

To prevent corrosion, wipe the exterior occasionally with a clean and soft cloth. Use a damp cloth containing a neutral cleaner to wipe off all oil or dirt build up.

2. Storage Bin and Scoop

* Wash your hands before removing ice. Use the plastic scoop provided (Accessory).

- * The Storage Bin is for ice use only. Do not store anything else in the bin.
- * Keep the scoop clean. Clean it by using a neutral cleaner and rinse thoroughly.
- * Clean the bin liner by using a neutral cleaner. Rinse thoroughly after cleaning.

3. Air Filter

The plastic mesh Air Filter removes dirt or dust from the air, and keeps the Condenser from getting clogged. As the filter gets clogged, the icemaker's performance will be reduced. Check the filter at least twice a month. When it is clogged, use warm water and a neutral cleaner to wash the filter.

4. Condenser

Check the Condenser once a year, and clean if required by using a brush or vacuum cleaner. More frequent cleaning may be required depending on the location of the icemaker.

C. Preparing the Icemaker for Long Storage

IMPORTANT

When shutting off the icemaker for an extended time, drain out all water from the water lines and remove the ice from the Storage Bin. The Storage Bin should be cleaned and dried. Drain the icemaker using air or carbon dioxide to prevent damage to the water supply lines at sub-freezing temperatures. Shut off the icemaker until the proper ambient temperature is resumed.

When the icemaker is not used for two or three days, it is sufficient to only move the Control Switch to the "OFF" position, unless the icemaker will be at sub-freezing temperatures.

1. Remove the water from the potable water supply line:

- 1) Remove the Louver if it has not already been removed.
- 2) Move the Control Switch on the Control Box to the "OFF" position.
- 3) Wait 3 minutes.
- 4) Close the potable water supply line Shut-off Valve and open the potable water supply line Drain Valve. See Figs. 4 and 5.

- 5) Allow the line to drain by gravity.
- 6) Attach compressed air or carbon dioxide supply to the potable water supply line Drain Valve.
- 7) Move the Control Switch to the "ICE" position.
- 8) Quickly blow the potable water supply line out using compressed air or carbon dioxide.

2. Drain the potable Water Tank:

- 1) Move the Control Switch to the "SERVICE" position and the Service Switch to the "DRAIN" position.
- 2) After 2 minutes, move the Control Switch to the "OFF" position.
- 3) Open the Door. Remove all ice from the Storage Bin and clean the Storage Bin.
- 4) Close the Door.
- 5) Replace the Louver in its correct position.
- 6) Turn off the power supply at the breaker box.
- 7) Close the potable water supply line Drain Valve.